

Considerations in Grounding and Shielding Audio Devices*

STEPHEN R. MACATEE, AES Member

Rane Corporation, Mukilteo, WA 98275, USA

Many audio manufacturers, consciously or unconsciously, connect balanced shields to audio signal ground. This is the source of many audio interconnection hum and buzz problems. The options available to manufacturers who follow this improper practice are discussed. Both balanced and unbalanced schemes and their incompatibilities are covered. Many manufacturers may already follow proper interconnecting practices. Those who are not have many options, including doing nothing.

0 INTRODUCTION

Now that the Audio Engineering Society has adopted the "pin 2 is hot" standard, the question of what to do with pin 1 is being addressed. A recommended practices document is being created covering interconnection of professional audio equipment. How and where to connect pin 1 is too complex to be issued as a standard; thus only a recommended practice is being developed. The recommended practices may affect manufacturers who choose to follow them.

Many shield-wiring practices exist in the audio industry today. The majority of available literature on the subject prescribes clear solutions to any wiring problem, yet problems are rampant due to inconsistent variations on the well-documented ideal. Two clear groups have developed on either side of a hard-to-straddle fence—the balanced world and the unbalanced world.

Over the past decade the declining cost of professional audio equipment has facilitated its use in more and more home studio environments. As home studios incorporate professional, balanced equipment into their systems, the unbalanced and balanced worlds collide. Home studios adding balanced equipment to their traditionally unbalanced gear also add connectivity problems. Professional users never consider unbalanced gear, yet still have connectivity problems.

The performance of any interconnection system is dependent on input/output (I/O) circuit topologies (specific

balanced or unbalanced schemes), printed-circuit-board layout, cables, and connector-wiring practices. Only wiring practices, both in the cable and in the box, are covered here. The I/O circuit topologies are assumed ideal for this discussion to focus on other interconnection issues.

The AES recommendation will address a simple issue, the absurdity that one cannot buy several pieces of professional audio equipment from different manufacturers, buy off-the-shelf cables, hook it all up, and have it work hum- and buzz-free. Almost never is this the case. Transformer isolation and other interface solutions are the best solutions for balanced-unbalanced interconnections, though they are too costly for many systems. Even fully balanced systems can require isolation transformers to achieve acceptable performance. Some consider isolation transformers the *only* solution. These superior solutions are not covered here.

Another common solution to hum and buzz problems involves disconnecting one end of the shield, even though one cannot buy off-the-shelf cables with the shield disconnected at one end. The best end to disconnect is unimportant in this discussion. A one-end-only shield connection increases the possibility of radio-frequency (RF) interference since the shield may act as an antenna. The fact that many modern-day installers still follow the one-end-only rule with consistent success indicates that acceptable solutions to RF issues exist, though the increasing use of digital technology increases the possibility of future RF problems. Many reduce RF interference by providing an RF path through a small capacitor connected from the lifted end of the shield to the chassis.

The details of noise-free interconnections and proper

* Presented at the 97th Convention of the Audio Engineering Society, San Francisco, CA, 1994 November 10-13; revised 1995 April 3.

grounding and shielding are well covered in other literature. They are not revisited here. Readers are encouraged to review bibliography listings for further information. Most of these materials have been applicable in the audio industry for well over 50 years, though until now they have not been implemented or embraced by many.

0.1 Balanced versus Unbalanced Shields

For the ensuing discussion, the term shield is qualified with the description balanced or unbalanced. An unbalanced return conductor physically resembles a shield and provides shielding for electric fields, but magnetic fields are not shielded. Though this is also true for balanced shields, the twisted-pair construction of balanced cables provides much greater immunity to magnetic field interference. Unbalanced cable shields also carry signal in the form of return current, further alienating unbalanced shields from "true" shields. Shield is defined by Ott [1] as "... a metallic partition placed between two regions of space. It is used to control the propagation of electric and magnetic fields from one place to another." A balanced interconnection provides the superior interface of the two.

0.2 The "Pin 1 Problem"

Many audio manufacturers, consciously or unconsciously, connect balanced shields to audio signal ground-pin 1 for three-pin (XLR-type) connectors, the sleeve on 1/4-in (6.35-mm) jacks. Any currents induced into the shield modulate the ground where the shield is terminated. This also modulates the signal referenced to that ground. Normally great pains are taken by circuit designers to ensure "clean and quiet" audio signal grounds. It is surprising that the practice of draining noisy shield currents to audio signal ground is so widespread. Amazingly enough, acceptable performance in some systems is achievable, further providing confidence for the manufacturer to continue this improper practice-unfortunately for the unwitting user. The hum and buzz problems inherent in balanced systems with signal-grounded shields have given balanced equipment a bad reputation. This has created great confusion and apprehension among users, system designers as well as

equipment designers.

Similar to the "pin 2 is hot" issue, manufacturers have created the need for users to solve this design inconsistency. Until manufacturers provide a proper form of interconnect uniformity, users will have to continue their struggle for hum-free systems, incorporating previously unthinkable practices.

0.3 The Absolute, Best Way to Do It

Clearly, the available literature prescribes balanced interconnections as the absolute, best way to interconnect audio equipment. The use of entirely balanced interconnection with both ends of the shield connected to chassis ground at the point of entry provides the best available performance.

The reasons for this are clear and have been well documented for over 50 years. Using this scheme, with high-quality I/O stages, guarantees hum-free results. This scheme differs from current practices in that most manufacturers connect balanced shields to signal ground, and most users alter their system wiring so that only one end of the shield is connected. Due to these varied manufacturer and user design structures, an all-encompassing recommendation with proper coverage of both balanced and unbalanced interconnections is essential.

Conceptually it is easiest to think of shields as an extension of the interconnected units' boxes (Fig. 1). Usually metallic boxes are used to surround audio electronics. This metal "shell" functions as a shield, keeping electromagnetic fields in and out of the enclosure. For safety reasons the enclosures in professional installations are required by law to connect to the system's earth ground (which in many systems is not the planet Earth-an airplane is a good example).

1 SPECULATIVE EVOLUTION OF BALANCED AND UNBALANCED SYSTEMS

One may ask: if the balanced solution is best, why is it that all equipment is not designed this way? Well, reality takes hold; unbalanced happens.

Back in the early days of telephone and AC power

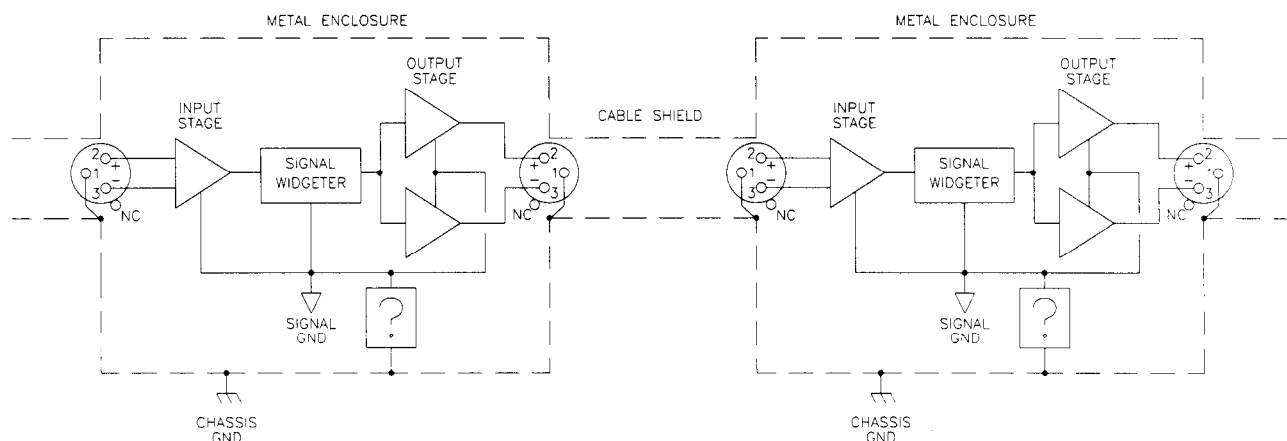

Fig. 1. Balanced cable shields should function as an extension of the enclosure.

distribution a specific class of engineers evolved. They learned that telephone and AC power lines, due to their inherently long runs, must be balanced to achieve acceptable performance. (To this day, many telephone systems are still balanced and unshielded.) In the 1950s hi-fi engineers developed systems that did not necessitate long runs, and they used unbalanced interconnections. The less expensive nature of unbalanced interconnections also contributed to their use in hi-fi. These two classes of engineers evolved with different mind-sets, one exclusively balanced, the other exclusively unbalanced. The differing design experiences of these engineers helped form the familiar balanced and unbalanced audio worlds of today.

Now add spice to the pot with the continued price decrease and praise devoted to balanced "professional" audio interconnections with the desire for better audio performance at home, and one sees the current trend of merging balanced and unbalanced systems arise. Home studio owners, previously on the unbalanced side of the fence, dream to jump but unfortunately straddle the fence, getting snagged on the fence's ground barbs when connecting their new balanced equipment (Fig. 2).

1.1 How Could This Happen?

To fulfill their users' desires to "go" balanced, hi-fi designers started upgrading equipment to balanced. From an unbalanced designer's mind-set, connecting the new balanced circuit's shield to ground is almost subconscious. This issue of which ground connects to the shield is alien or unknown. The old unbalanced "shield" (really the return signal conductor, not a true shield) is already "grounded." Without appropriate balanced interconnect research, this hi-fi mind-set may not think to *add* a chassis-grounded shield around the existing two-conductor cable. This redefines the "old" return conductor as a "new" negative signal carrier, not as a shield. It was perhaps the convenience of the situation and this mind-set that started improper signal grounding of balanced shields in the first place. Little treatment of this subject is given

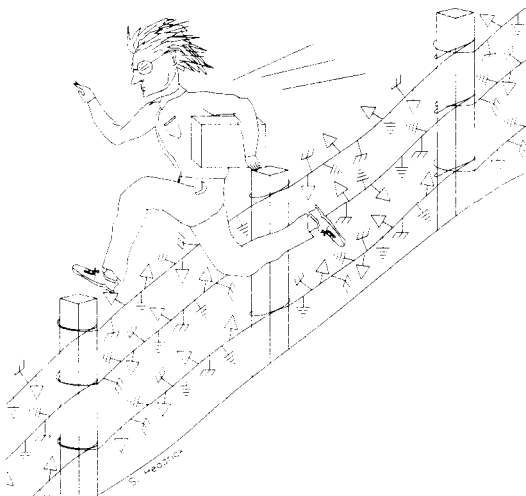

Fig. 2. Home studio owner trying to jump the balanced-unbalanced fence.

in educational institutions, and many systems happen to work satisfactorily even with improperly grounded shields.

Other designers, when upgrading to balanced interconnections, may have realized that by connecting the shield to signal ground, interfacing to unbalanced equipment is made simpler since signal ground (needed for unbalanced interconnections) will be available on the cable. [This, unfortunately, allows easy use of ¼-in (6.35-mm) mono connectors.] This still creates the same problem, signal-grounded balanced shields. Signal-grounded shields on balanced equipment create ground loops in the audio path and modulate the audio signal ground, wreaking havoc with most systems. This practice penalizes those who want to realize the superior performance of balanced interconnections and has given balanced interconnections a bad reputation.

A third possible reason for signal-grounded balanced shields arises if designers change phantom-powered microphone inputs to balanced line-level inputs and do not use caution. The phantom-power return currents travel through the shield, requiring shield connection to the signal ground. When changing this topology to line-level balanced inputs, the designer may not think to change the shield connection to the chassis ground. This issue is further complicated by manufacturers who incorporate ground lift switches in their products. Ground lift switches disconnect chassis and signal ground. Thus care should be taken to ensure that phantom-power return currents always have a return path to their power supply, regardless of the ground lift switch position.

Manufacturers who started in balanced fields, such as the telephone and broadcast industries, used chassis-grounded shields when maximum protection from electromagnetic interference (EMI), which includes RF, was necessary. Perhaps users from these balanced fields assumed that all balanced equipment had chassis-grounded shields. When improperly wired manufacturers' equipment was installed, they discovered hum and buzz problems. They solved them with isolation transformers, by disconnecting one end of the shield, or by simply not using that manufacturer's equipment. The feedback to inform manufacturers of their improper shielding practices never developed. Manufacturers may have suggested isolation transformers or cable rewiring solutions instead of addressing the cause of the problem—signal-grounded balanced shields. Again, some systems with signal-grounded shields work acceptable, causing further and future bewilderment.

1.2 The History Lesson

The lesson to be learned from this account involves keeping in mind these audio interconnection issues when specifying, designing, or upgrading other connectivity systems such as AES/EBU, SPDIF, and other electrical interfaces. Balanced and unbalanced systems are not designed to interface together directly. As the audio industry embraces more digital products, interconnection systems must be clearly designed and specified for use within the limits of their electrical interfaces. Multiple-conductor connectors, carrying either digital or analog

signals, present even more challenges. The distance between units is an important issue. Keeping interconnections balanced and chassis ground shielded provides the best possible immunity from EMI, regardless of cable lengths. Unbalanced interconnections may be less expensive to manufacture and sell, but perhaps are more expensive to install-hum- and buzz-free.

The Audio Engineering Society is to be applauded for assembling and disseminating this information to those who may be unfamiliar with it. Manufacturers and, more importantly, users will eventually be rewarded.

2 CHASSIS GROUND VERSUS SIGNAL GROUND

Let us examine the distinction between chassis and signal ground in audio devices. Chassis ground is generally considered any conductor that is connected to a unit's metal box, or chassis. The term chassis ground may have come about since units with three-conductor line cords connect the chassis to earth ground when plugged into a properly wired AC outlet. In units with a two-conductor line cord (consumer equipment) the chassis does not connect to earth ground, though it is normally connected to the signal ground in the box.

Signal ground is the internal conductor used as the 0-V reference potential for the internal electronics and is sometimes further split into digital and analog ground sections. Further signal ground splits are also possible, though it is important to remember that all "divisions" of signal ground connect together in one place. This is usually called a star grounding scheme.

It is easy to confuse chassis ground and signal ground since they are usually connected together, either directly or through one of several passive schemes. Some of these schemes are shown in Fig. 3. The key to keeping an audio device immune from external noise sources is knowing *where* and *how* to connect the signal ground to the chassis.

First let us examine why they must be tied together. We shall cover where and how in a moment. There are at least two reasons why one should connect signal ground and chassis ground together in a unit.

One reason is to decrease the effects of coupling electrostatic charge on the chassis and the internal circuitry. External noise sources can induce noise currents and electrostatic charge on a unit's chassis. Noise currents induced into the cable shields also flow through the chassis, since the shields terminate (or should terminate) on

the chassis. Since there is also coupling between the chassis and the internal circuitry, noise on the chassis can couple into the internal audio. This noise coupling can be minimized by connecting the signal ground to the chassis, which will allow the entire grounding system to fluctuate with the noise, surprisingly providing a quiet system. Further coupling reduction is gained when the chassis is bonded solidly to a good earth ground—either through the line cord, through the rack rails, or with an independent technical or protective ground conductor. This provides a nonaudio return path for any externally induced noise.

The second reason for connecting signal ground to the chassis is the necessity to keep the signal grounds of two interconnected units at very nearly the same voltage potential. Doing so prevents the loss of system dynamic range where the incoming peak voltage levels exceed the power supply rails of the receiving unit.

Unbalanced units connect successive signal grounds together directly through each interconnecting cable, the sleeve of each RCA cable. This—and the fact that the chassis is generally used as a signal ground conductor—keeps the signal ground impedance of unbalanced systems very low. Many may agree that unbalanced systems are helped by the fact that the chassis are normally not earth grounded. This allows an entire unbalanced system to float with respect to earth ground. It eliminates the potential for multiple return paths for the audio grounding system, since there is no second path (ground loop) through the earth ground conductor. Low signal ground impedance between units is essential for acceptable operation of all non-transformer-isolated systems, balanced and unbalanced.

The design of balanced interconnections does not connect signal grounds directly together. The negative conductor provides the required signal return current. To avoid loss of dynamic range, balanced systems use a different method of keeping signal ground potentials small.

Since the cable shield already connects the two chassis together, simply connecting the signal ground to the chassis in each box keeps the signal ground potentials between units small. The key is how to connect them. Since the cables between units also provide the shortest (and therefore the lowest impedance) path between two units, using the cable shield to minimize the signal ground potentials between units is quite effective.

Now that we know why one must connect the signal ground to the chassis, let us discuss how to connect them. The schemes in Fig. 3 appear straightforward enough, but what is not shown is precisely where and how the conductors connect together. It all comes down to paying close attention to where currents flow. As discussed, the shield noise currents flow through the chassis and shunt to earth ground on units with three-conductor line cords. The key issue is that these noise currents do not flow through a path shared by any audio currents. It seems so simple, and is—especially to draw (see Fig. 3 again). The hard part is implementing the proper layout scheme.

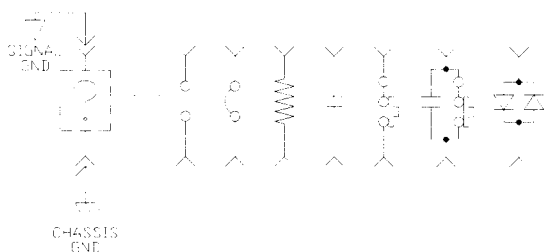

Fig. 3. Some passive schemes for connecting signal ground to chassis.

Connecting the signal ground to the chassis in each unit can only be done in one place in each unit. If done twice, one leaves the possibility open that the noise currents will flow through a path shared by audio.

There are two schools of thought on where to connect the signal ground to the chassis. They are both versions of the star ground scheme mentioned. The first connects a trace (or wire) directly from the audio power supply ground terminal to the chassis ground point (Fig. 4). It is important, in both schools, that no other signal currents be allowed to flow through this trace. Do not allow this trace to share any other return currents from other signal-grounded circuit points, such as the input or output circuit's ground. This keeps chassis noise currents from flowing through the same trace, which is a return path for an audio signal. Also keep in mind that this trace may contain noise currents and should be kept away from noise-sensitive circuitry. This is a star grounding scheme, which uses a point originating at the output of the power supply as the center of the star. There are two common locations in the power supply for the star's center—the output terminal of the power supply and the point between the AC filter capacitors.

Another school of thought on where to connect the signal ground to the chassis simply moves the center of the star ground to the input jack's ground. This scheme makes the most sense for unbalanced units and for balanced units equipped with 1/4-in (6.35mm) connectors where the use of mono plugs is possible.

3 MANUFACTURER ISSUES TO ADDRESS

Implementing their users' desires to "upgrade" to balanced, traditionally unbalanced manufacturers are faced with an important issue: How do you solve the balanced-unbalanced incompatibility problem? If you sell your product to a mixed balanced-unbalanced market, a suggested method of interconnection must be available. Isolation transformers and active interface boxes are the

best solution and should be offered as the best interconnection alternative. However, persuading unbalanced customers to buy an expensive interface solution is much harder than the lower performance option of rewiring their cables. (The add-on transformer solution is analogous to a software company releasing a new software revision which renders your existing files incompatible unless an additional file conversion program is purchased.)

Through careful rewiring of the cables, acceptable interconnection solutions are achievable in some systems. (One of Rane's most popular technical notes, Rane Note 110 [2], now being rewritten, is one example of the "custom" wiring needed in some systems.) This same cable rewiring solution holds whether the equipment is wired with signal ground or with chassis ground on the balanced circuit's shields.

4 SOLUTIONS FOR MIXED BALANCED AND UNBALANCED SYSTEMS

It is obvious from the vast quantity of literature that for fully balanced operation, the shield should connect to the chassis ground at the point of entry. This is also true for unbalanced operation when a third shield conductor is available. Connect the shield to the chassis ground at the point of entry. However, this is only valid when two-conductor shielded cable is used.

4.1 Shielded Two-Conductor Connectivity

Fig. 5 shows recommended wiring for all combinations of balanced and unbalanced I/O interconnections when two-conductor shielded cable is used. It also includes the two most common manufacturer shield-grounding schemes—signal grounding the shield and chassis grounding the shield. Identifying these schemes for every unit in a system is essential to debug system hum and buzz. This is no simple task since chassis and signal grounds may be connected together. The goal is

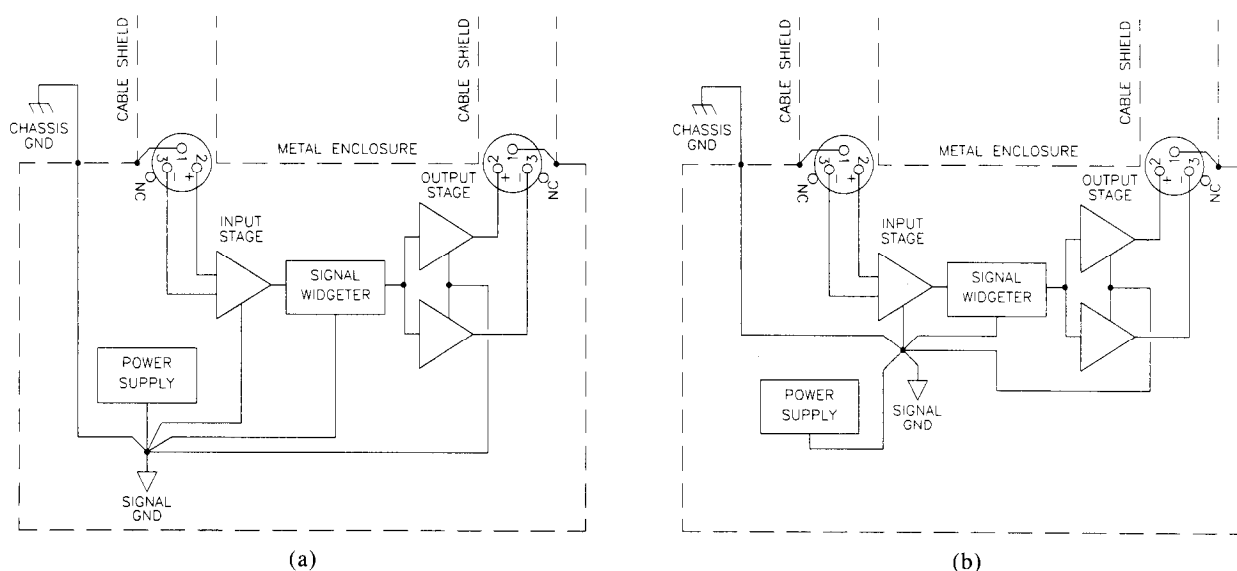

Fig. 4. Two star ground schemes for connecting signal ground to chassis. (a) Star center at power supply. (b) Star center at input ground.

to find out if the manufacturer connected them together in such a way that shield currents do not affect the audio signal. The dashed lines in Fig. 5 represents the units' chassis boundaries. Connections between dashed lines are functions of the cable. Connections outside these lines are the manufacturers' choosing, whether conscious or unconscious.

Fig. 5 is arranged such that the top and leftmost drawing [Fig. 5(a)] is the theoretical "best" way to connect equipment with optimal results. "Best" way means that everything is completely balanced with all shields (pin 1s) connected to the chassis ground at the point of entry. As one moves down or to the right, degradation in performance is expected. Whether a system operates acceptably or obeys these theoretical predictions is too system specific to predict accurately. However, one must start somewhere.

The quality and the configurations of the input and output circuits are omitted from Fig. 5 and the ensuing discussion to focus on cable wiring and the internal wiring of the units. The I/O circuitry is assumed ideal.

4.2 Fully Balanced

Fully balanced systems (left column in Fig. 5) provide the best performance when both ends of the shield connect to units with chassis-grounded shields [Fig. 5(a)]. When units with signal-grounded shields are encountered, disconnect the shields at the signal-grounded ends [Fig. 5(b) and (c)]. This keeps the induced shield currents out of the audio signal ground. If both units involved have signal-grounded shields, you have entered the twilight zone [Fig. 5(d)]. This is perhaps the most common scheme. Most disconnect one end of the shield. Specifically which end is disconnected creates strong political debates and is left for the individual user to decide. Never disconnect both ends of a shield.

4.3 Unbalanced Output Driving Balanced Input

The second column in Fig. 5 shows unbalanced outputs driving balanced inputs. Again only shielded two-conductor cable is used. The best case here has both ends of the shield connected to units whose shield is chassis grounded [Fig. 5(e)]. Some may argue that the induced noise on the signal conductors may be injected into the "sending" unit through the unbalanced output stage. This is a function of the system and the output circuit and is quite likely. Disconnecting the shield at the unbalanced output may help reduce this problem.

Again, when units with signal-grounded shields are encountered, disconnect the shields at the signal-grounded ends [Fig. 5(f) and (g)]. This keeps the noisy shield currents out of the audio signal ground. If both units involved have signal-grounded shields, you have entered the twilight zone again [Fig. 5(h)]. Support your favorite one-end-only political party.

4.4 Balanced Output Driving Unbalanced Input

The third column in Fig. 5 is the most troublesome, balanced outputs driving unbalanced inputs. Since the input stage is not balanced, induced noise on the signal conductors is not rejected. If you must use an unbalanced input, use as short an input cable as possible. This reduces the induced noise. Fig. 5(i) shows both ends of the cable shield connected to units with chassis-grounded shields. If the units are far apart, the chance of the shield currents inducing noise on the signal conductors is greater. Keeping this cable very short reduces the shield current and therefore reduces the noise that is *not* rejected by the unbalanced input stage. Most systems may require disconnecting one end of the shield for the Fig. 5(i) case. Even a small current in the shield may prove too much for an unbalanced input stage. Again,

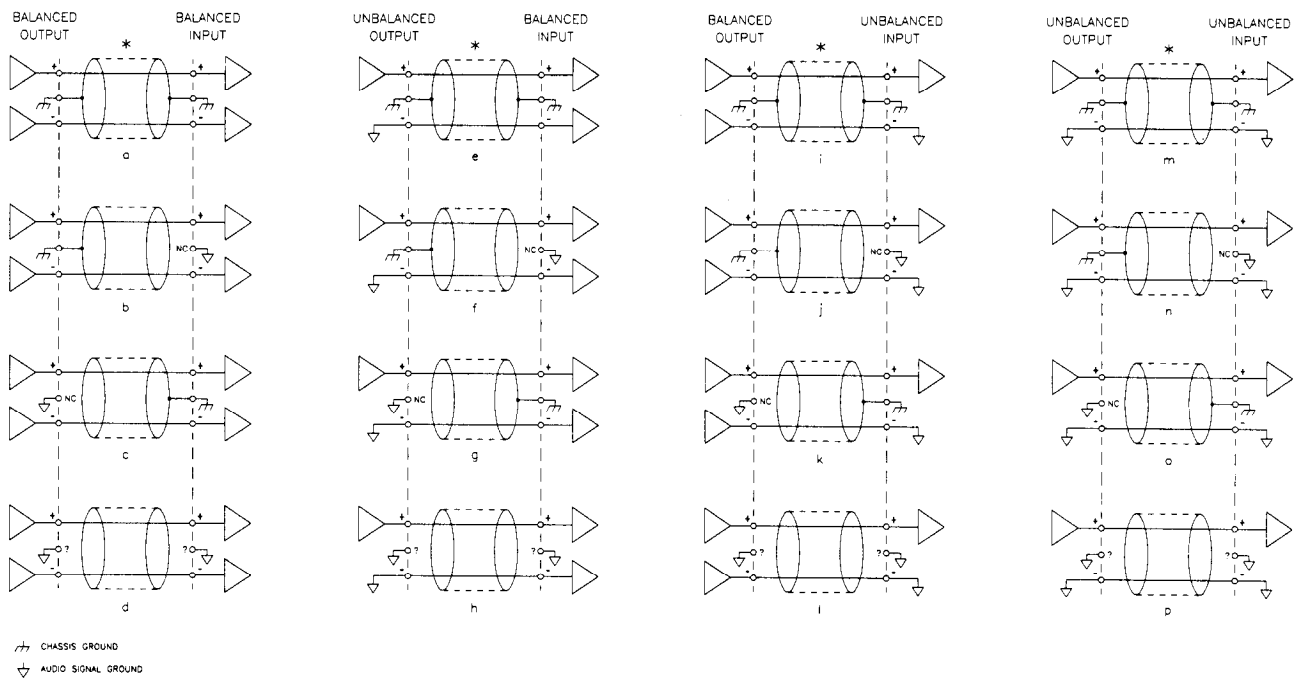

Fig. 5. Interconnectivity using shielded two-conductor cable only. Asterisks denotes usability with off-the-shelf cable.

support your favorite one-end-only position.

Disconnect the shields at units with signal-grounded shields [Fig. 5(j) and (k)]. If both ends have signal-grounded shields, run for your favorite one-end-only political party [Fig. 5(l)].

This scheme connects the balanced output's negative output to the signal ground rather than a high-impedance input. Many balanced output circuits will attempt to drive this signal ground, causing great distortion and potentially damaging the output stage. Other balanced output stages are termed "floating" balanced. (The Analog Devices SSM-2142 balanced line driver chip is one example.) Also called a cross-coupled output, these circuits mimic the performance of fully balanced transformer solutions and are designed so that the negative output can short-circuit to the signal ground. If you find or use this scheme, be sure that the balanced output stage can properly handle the signal ground on its negative output.

4.5 Full Unbalanced

Fully unbalanced systems rarely provide a three-conductor connector to enable proper use of a shield. In the unlikely event that you run across one, use the wiring in the fourth column. Again keeping cable lengths short will reduce noise problems, with or without a shield [Fig. 5(m) - (p)].

Most home audio systems are fully unbalanced. Millions of these systems work virtually hum- and buzz-free every day, due to their small nature, short cable runs, and two-conductor AC line cords. The headaches begin when one tries to add a balanced unit to such a system. In unbalanced home audio products neither of the line cord's conductors connects to the chassis, since plugging older nonpolarized AC plugs into an improperly wired outlet would place the hot wire on the unit's chassis. Lack of the third pin on the line cord prevents ground loops in home systems since a second path to ground, or between units, is unavailable. Professional audio equipment generally comes equipped with a three-wire line cord. The third wire (green wire) is required to connect to the chassis. This provides the second ground path (loop) from one unit to the next.

4.6 Connector Choice

The connector type was purposely left out of Fig. 5 and the preceding discussion since connector choice adds another layer of complexity to interconnection systems. The most troublesome culprit is the 1/4-in (63.5-mm) connector. Mono 1/4-in connectors are used on most musical instruments and in phone systems. Stereo 1/4-in connectors are used for headphones, balanced interconnections, effect and insert send and return loops, relay switch closure points, and an extravagant collection of other miscellaneous connections. Murphy's law tells us that if you provide such a diverse selection of 1/4-in interconnecting options, they will be hooked up improperly. The audio industry's problem is that many of these options are completely incompatible. A properly wired mono 1/4-in connector has the signal ground on the

sleeve, a properly wired balanced 1/4-in connector has the chassis ground on the sleeve. Interconnecting this combination should not be achievable-much like trying to connect 120 V AC to an RCA jack (see Fig. 6). The 1/4-in connector's low cost, high availability, and small size all contribute to its widespread and varied use. Undoubtedly the numerous interconnection uses of such a popular connector arose for these reasons.

Sadly, the possibility of including the connector type in a recommended practices document is slim. To duplicate connectors on many audio components contributes to higher costs and wastes millions of dollars worth of connectors that are never used. Some manufacturers are attempting to eliminate the 1/4-in connector to avoid the confusion and problems when 1/4-in jacks are used. This is a step in the right direction, though the high density allowed by these connectors requires less valuable rear-panel real estate. Most marketing departments prefer 30 connectors per inch, making the currently available three-pin (XLR) alternative markedly unpopular. What is needed is a three-pin connector solution that requires less space than the traditional XLR connector. A locking, stackable three-pin mini-DIN comes to mind.

Terminal block and Euroblock connector types are used when separate cable-end connectors are unnecessary or impractical. These connection solutions provide the user with the most wiring options when both signal and chassis ground terminals are available. It allows the user to decide which wiring practice to incorporate. This is the most desirable solution, though most studio equipment does not call for these connector types.

4.7 "Hidden" Balanced I/O Solution

An interesting solution for mono interconnection incorporates unshielded balanced stages, much like most telephone systems. Fig. 7 shows this configuration. This allows off-the-shelf mono cables to be used to connect unbalanced or unshielded balanced I/Os to a system. Though not as ideal as a shielded balanced interconnection, systems with mono connectors, such as home theater systems, benefit from this configuration. Keeping cable lengths short is essential and not difficult in a home environment.

One advantage of such a system-besides making it impossible, on fully balanced systems, to get the signal ground on an external cable-is that it provides an easy upgrade path to balanced signal connections. The manufacturer need only change the connector to a three-pin version. Also crucial for this solution is the need to have cross-coupled output stages, since the negative output

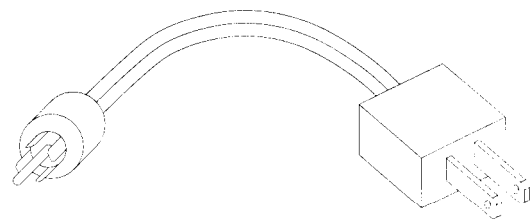

Fig. 6. Difficult-to-find connector type

may connect to the signal ground.

A slight disadvantage lies with the common use of nontwisted-pair cables in off-the-shelf mono cables. Using twisted cable with this unshielded balanced scheme greatly improves the achievable performance.

4.8 The Muncy Solution

Neil Muncy, an electroacoustic consultant and veteran of years of successful system design, chairs the AES committee working on these interconnection issues. His long-standing solution to these issues provides real-world proof of the guaranteed performance achievable with fully balanced systems wired per the AES recommendation. Mr. Muncy implements what I call the Muncy solution and alters every piece of gear such that it has balanced inputs and outputs with both ends of the shield connected to the chassis ground at the point of entry. Years of this practice, and the early research and discipline to understand the basic physics required to implement it properly, have given Mr. Muncy the drive to tirelessly tour the country dispersing his findings. Mr. Muncy's seminars educate those who are ignorant of the "right" way to wire balanced equipment, and show the advantages gained when every piece of gear in the system is wired accordingly.

4.9 Current Manufacturer Solutions

Let us examine manufacturers' choices regarding signal grounding or chassis grounding balanced cable shields. The problems of signal grounding balanced shields have already been covered. Users choose to live with hum and buzz, alter off-the-shelf cables by disconnecting one end of the shield, or, even in fully balanced systems, use isolation transformers. All are senseless alternatives for inconsistent manufacturing methods. Their advantages and disadvantages are outlined in Tables 1 and 2.

For the manufacturer, several shield connectivity choices are available.

1) *Keep or change shield connections to the chassis ground.* Manufacturers who chassis-grounded balanced shields originally must still recommend isolation transformers, cable altering, and the technical support that go with these hum and buzz solutions. This is unfortunately

necessary since not all balanced equipment has chassis-grounded shields. Ideally, if *all* balanced equipment were suddenly and miraculously chassis grounded on both ends, off-the-shelf cables could be used in every system, leaving only the I/O circuitry to dictate system performance.

2) *Change shield connections to the signal ground.* Though this would be a step backward, it is still a choice. Most equipment is connected this way, and most users have found their own costly add-on interconnection solutions.

3) *Offer the shield connection choice to the user.* Provide both options. With two independent screw terminals (one signal, one chassis), a switch or a jumper option will permit users to wire as they please. More on this later.

5 MANUFACTURER SOLUTIONS FOR EFFICIENTLY AND EFFECTIVELY CONNECTING BALANCED SHIELDS TO THE CHASSIS

5.1 Printed-Circuit-Board-Mounted Jacks

The printed-circuit-board-mounted jack provides manufacturers with the most cost-effective solution for transferring cable signals to a printed-circuit board. On the printed-circuit board most manufacturers connect the balanced shield conductor (to signal ground) with a board trace. For optimum balanced performance connect the shield to the chassis ground at the *point of entry*. This means that the shield conductor, to avoid spraying any induced RF energy into the box, never passes the chassis' outer plane. This is not a simple task. Currently no printed-circuit-board-mounted three-conductor connectors provide this optimum solution.

5.2 Terminal Strips

When both signal and chassis ground terminals are provided on terminal block or Euroblock connector types, the user decides which wiring practice to incorporate. This is a desirable solution, though a lot of equipment does not call for these connector types. Providing a Pem nut, screw, and toothed washer near the cable

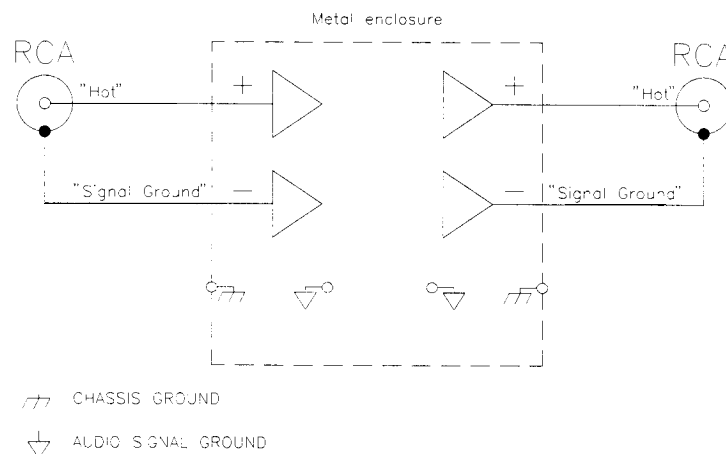

Fig. 7. "Hidden" balanced interconnection.

terminals, instead of an additional chassis-grounded screw terminal, prevents the shield conductor from entering the enclosure-supplying the ultimate interconnection solution. Users select their preferred wiring practice, and the shield cannot spray RF into the enclosure. Maintaining the shield around the signal conductors all the way to the I/O terminals is important. Keeping the Pem screw near the terminals is therefore essential.

5.3 Panel-Mount Jacks with Wires

Panel-mount jacks require the manufacturer to connect a wire from a terminal pin to the printed-circuit board or chassis. This is a good solution for chassis grounding a shield, though this allows the shield to enter the enclosure. Keep the wire short, the gauge large, and the path to the chassis away from sensitive circuits. "Wire" is a four-letter word to many manufacturers, and some consider wires too costly due to their labor-intensive nature. Achieving consistent results with hand-wired connections is difficult, making the printed-circuit-board-mounted jack solution more desirable.

5.4 L-Bracket or Standoff Solution

A circuit-board trace run to a nearby chassis-grounded point is another option. The use of an L bracket, standoff, or similar mechanical connection to the chassis provides mechanical stability, but also consumes valuable rear panel or printed-circuit-board real estate at the same time. Important here is avoiding long traces and keeping the trace away from sensitive areas since it acts as a noise source when shield currents are large or noisy.

5.5 Jumper Options

Not as "friendly" as the screw terminal solution, an internal jumper option provides user configuration of internal shield connection points. This allows the use of XLR or ¼-in (6.35-mm) connectors, yet still gives the

user control of shield wiring practices. Providing a separate, external switch for this function is not cost-effective. Two issues arise with this solution. The first is that there is no external visual indication showing the shield connection point. The second issue to address is which position to ship the jumpers in.

The first problem is nothing new. Most manufacturers do not specify where their shields are connected. The unit's manual or its schematic, if available, may indicate which ground connects to the shield. The schematic symbols used for grounds are not standardized, though there is an AES standards group addressing drafting symbols to solve the dangling-triangle mystery. Proper schematics indicate which symbols represent signal and chassis grounds. The second issue's answer is clear-chassis grounding the balanced shield is the "best" default option, though offering the choice supplies an elegant solution for parties on both sides of the fence. For fully balanced systems, defaulting the shield jumper to the chassis provides the best solution, but only when all interconnected units have chassis-grounded shields. Other units with signal-grounded shields short-circuit the shield currents to the signal ground when connected, causing potentially nasty modulation of the signal ground. This makes the other guy appear the culprit, but does nothing to solve the problem. Clearly users must be able to determine the manufacturer's shield wiring practices. In addition, to support both one-end-only shield connection parties, separate input and output jumpers must be provided (Fig. 8).

5.6 Neutrik Solution

Neutrik AG, Liechtenstein, offers snap-in printed-circuit-board-mounted jacks with metal brackets that pierce the inside of the chassis when external mounting screws are installed. This chassis-pierced bracket also has a separate pin available through the printed-circuit board. The sharp piercing tab provides the electrical connection between the chassis housing and the printed-circuit board. This solves the problems of the labor-intensive wiring and the need to connect to a chassis point, providing the best solution for manufacturers and users. [Neutrik's popular "combo" receptacles—combined female XLR and female ¼-in (6.35-mm) connectors—provide this piercing tab feature.] Unfortunately, depending on the available height in a given unit, these jacks have trouble fitting into a single-rack space unit due to their slightly larger heights. Hopefully other jacks with this built-in feature will become available, providing manufacturers with a cost-effective solution to this grounding problem. The other problem with these connectors is that only the female connector has this piercing tab.

5.7 Other Suggestions

While doing research for this paper a few more important concepts and discussions were uncovered that warrant mentioning. Martin Glasband has written a series of articles on balanced AC systems [3], [4]. Glasband applies the same balanced concepts used in audio inter-

Table 1. Signal-grounded balanced shields.

Advantages	Disadvantages
Permits mono ¼-in (6.35mm) cable use if proper I/O stage is present.	Hum and buzz is present. Must alter cables to interface with many components. Use of isolation transformers and/or interface boxes is needed in some systems. Most manufacturers do it this way.

Table 2. Chassis-grounded balanced shields.

Advantages (with Ideal I/O Circuitry)	Disadvantages
Use of off-the-shelf cable is permitted. No hum and buzz occurs. No isolation transformers or add-on solutions are needed.	Mono ¼-in (6.35mm) cables cannot be used. Few manufacturers do it this way.

connection to AC power systems. Common 120-V AC single-phase circuits, like their unbalanced counterparts, have grounded (earthed in this case) "return" conductors. This creates differing impedances to ground on the two signal conductors—the 120-V AC "hot" lead and the neutral. Glasband suggests using a balanced AC system, where the power transformer's center tap is grounded and a balanced 120-V source is created from the positive and negative secondary windings (Fig. 9). The National Electrical Code does not mention properly grounded 120-V two-phase wiring systems [5], though several installations incorporating balanced alternating current of this type have been approved through careful education of the inspector (and the inspector's supervisor).

This balanced AC power scheme really strikes at the heart of another problem. Audio power supplies are not designed to operate from the unbalanced alternating current they are commonly fed. Power supply return currents simply build up on the neutral conductor, adding more noise to the AC ground system. Return currents in balanced AC systems appear out of phase at the transformer secondary and cancel. This balanced 120-V two-phase system is not much different from the common 240-V (dryer) system found in most homes. The transformer provides both 120 and 240 V, the 240 V from the out-of-phase positive and negative secondary windings. (This is similar to Fig. 9, except with the secondary voltages doubled.) Although these 120-V two-phase systems may be currently unorthodox and difficult to install legally, once some of the safety issues are solved, the benefits for audio systems may live up to the potential improvement achievable—unlike balanced audio interconnections. It is hoped that the bad reputation of balanced audio interconnections will not last much longer.

Many years ago RCA developed their own guidelines for rear-panel I/O practices. Some manufacturers and users practice their own methods of left-to-right interconnection customs. Alternating current and loudspeaker-level I/O circuitry on one side, microphone and lower level signals on the other side. This permits easier rack wiring and decreases crosstalk between cable runs in the rack and along cable paths. While the recommended practices document may not dictate product design at

such a basic level, this type of thinking benefits everyone. With multimanager standardized network-controlled products still near their infancy, now is the time to address these basic features. Users with "standardized" interconnection systems, designed by informed engineers with the user in mind, will spend less time debugging and installing systems. This allows more installations per day, generates better, quieter systems, and provides more business with smiling users *and* manufacturers.

6 FIBER IS THE FUTURE

Digital fiber-optic interconnections will solve all the foregoing problems of electrical interconnection systems, though one must face a new set of problems. Fiber is difficult to terminate and split, potentially fragile, sensitive to ambient light when receivers are not covered, and, for now, expensive. However, when one adds up the debugging costs of eliminating hum from electric systems, fiber may no longer seem as expensive.

7 CONCLUSION

Balanced and unbalanced interconnections are two very different beings. The incompatibility between these two configurations, whether using analog or digital sig-

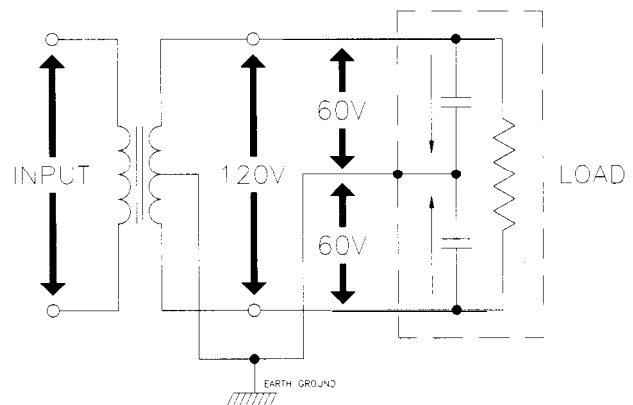

Fig. 9. 120-V two-phase (60-V) balanced power.

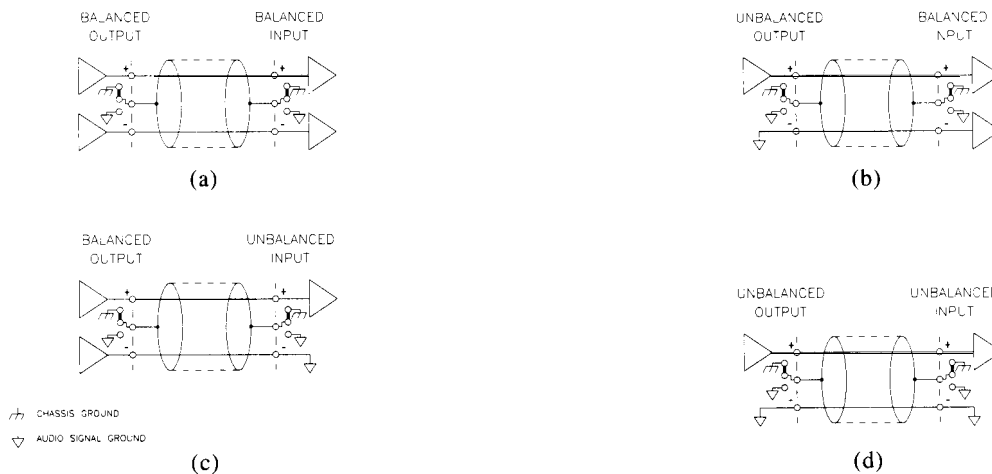

Fig. 8. User-selectable shield connections.

nals, must be considered when designing, specifying, installing, or upgrading equipment and systems. Literature on the subject of grounding and shielding audio devices dictates chassis grounding balanced shields. Most manufacturers, however, signal ground their balanced shields. Speculation about how and why this practice materialized was explored. The Audio Engineering Society is developing a recommended practices document which also condones chassis grounding balanced shields, among other things. It was shown that a manufacturer's choice of either signal grounding or chassis grounding balanced shields does not affect the cable rewiring and other technical support solutions normally recommended when interconnection of balanced and unbalanced equipment is needed. Therefore manufacturers need not hesitate in addressing their "pin 1 problems," and should provide users with the *real* benefits of balanced interconnections by providing chassis ground on balanced shields. Efficient and effective ways of doing this were also discussed.

Also covered was the importance of reducing signal ground voltages between interconnected units by carefully and properly connecting chassis ground to signal ground, in one place, in each unit. Vitaly important is the manner in which one connects these two grounds together. The same care must be taken when connecting I/O cable shields to the chassis ground. One must avoid common impedance coupling in the shield-to-chassis trace to ensure optimum performance from balanced interconnections.

The goal of the Audio Engineering Society in recommending these balanced interconnection solutions is to reduce or eliminate the need for interconnection alternatives through education and information sharing. This is the mission statement of the Audio Engineering Society in the first place. Systems installed with chassis-grounded balanced shields on all units, with well-twisted interconnecting cables operate hum- and buzz-free, leaving only the I/O circuit topology specifications to dictate system performance.

The AES recommendation's purpose is not to create another "pin 2 is hot" war. In reality, users and installers have found acceptable solutions for the "pin 1 problem" of signal-grounded balanced shields and are unlikely, nor will they be able, to suddenly change over to not

using alternatives. Manufacturers specify the I/O connector type on data sheets; similarly, we should specify shield connection practices in equipment specifications, on the chassis, or at least in the manual, thus providing users with the information required for proper system configuration.

8 ACKNOWLEDGMENT

The author wishes to thank Rick Jeffs of Rane Test Engineering and Neil Muncy of Muncy and Associates for keeping the author grounded to the real world during the hours of practical and sometimes frazzling discussions on grounding.

9 REFERENCES

- [1] H. W. Ott, *Noise Reduction Techniques in Electronic Systems* (Wiley, New York, 1976).
- [2] T. Pennington, *Rane Note 110* (Rane Corp., Mukilteo, WA, 1985).
- [3] M. Glasband, "Lifting the Ground Enigma," *MIX* magazine, vol. 18., no. 11, pp. 136-146 (1994 Nov.).
- [4] M. Glasband, "Audio Noise and AC Systems Revisited, Rethinking Studio Electrical Systems," *R•E•P*, vol. 23, no. 8, pp. 30-34 (1992 Aug.).
- [5] M. Glasband, "Audio Noise and AC Systems," *R•E•P*, vol. 22, no. 6, pp. 42-45 (1991 June).

10 BIBLIOGRAPHY

- Giddings, P., *Audio System Design and Installation* (Howard W. Sams, Indianapolis, IN, 1990).
- Jung, W., and A. Garcia, "Op Amps in Line-Driver and Receiver Circuits, Part 2," *Analog Dialogue*, vol. 27, no. 1 (1993).
- Metzler, B., *Audio Measurement Handbook* (Audio Precision, Portland, OR, 1993).
- Morrison, R. *Grounding and Shielding Techniques in Instrumentation* (Wiley, New York, 1967).
- Morrison, R., *Noise and Other Interfering Signals* (Wiley, New York, 1992).
- Perkins, C., "Measurement Techniques for Debugging Electronic Systems and Their Interconnection," in *Proc. 11th Int. AES Conf.*, Portland, OR (1992 May).

THE AUTHOR



Stephen Macatee is a design engineer with Rane Corporation in Mukilteo, WA. He received a BSEE from Monmouth College, NJ, in 1986, and started working in Rane's manufacturing department in 1987, stuffing and soldering boards. He soon moved to Rane's computer-aided design department where he helped design and develop Rane's customized computer-aided design system, and spent several years designing printed-circuit boards. In this capacity, he was able to apply his engineering background and manufacturing experiences to

optimize Rane's printed-circuit board designs for low-noise, high-performance operation and efficient manufacturing. Currently he focuses his efforts in the area of digital hardware and software design.

In his free time Mr. Macatee designs alternative MIDI controllers. His most recent project involved sensing a juggler's motions thus creating a bizarre new musical instrument from the juggler's movements. He also enjoys music, percussion, good food, working on his home and spending time with his wife, Jill.