

IMPROVING the WILLIAMSON AMPLIFIER

By TALBOT M. WRIGHT

Changing a few resistors in the driver section results in reduced distortion in this hi-fi amplifier design.

THE Williamson amplifier, whether it be of the classic triode type or the "Ultra-Linear" version, has to some extent fallen into disfavor with audiophiles since it is now possible to build an amplifier at lower cost and still equal or better the Williamson's performance.

Many Williamson owners have discarded their trusty old amplifiers in favor of 50 or 60 watts in the never-ending chase after unmeasurable distortion. Many Williamsons have been converted to higher powers by the use of newer tubes and heftier output transformers. In some cases the proud owner has realized an audible increase in definition and an accompanying drop in distortion.

Frequently such an experimenter will add a high-power output stage to his Williamson drive system—in most cases paying for 50 watts in order to get a clean 20 watts. Even then he doesn't always get the improvement he expects. The fault lies not in the power stage but in the drive system. The two main faults of the Williamson are distortion at me-

dium to high levels and instability. We'll discuss instability later—but first to the distortion.

IM Distortion

If you run an intermodulation distortion test on an average Williamson amplifier using the classic drive system you will find that the IM exceeds 2% at only slightly over half the rated power. By the time you reach rated power you find the distortion is well past the tolerable level. The result of this testing usually leads to a substitution of all the tubes in a wistful search for lower distortion. Sometimes this helps a little.

Basically the voltage amplifiers are producing much greater amounts of distortion than they should. "But," you say to yourself, "I followed the design scrupulously; even the voltages are what they should be." The point overlooked, however, is that the American 6SN7, 6CG7, or 12AU7 will not work well with the circuit values specified by Mr. Williamson in his original paper on the subject.

A careful inspection of any U.S. tube manual will disclose the fact that the 6SN7 or 6CG7, as used in the Williamson amplifier circuit, is badly under-biased.

Take the push-pull driver stage for instance. Usually the plate loads are 47,000 ohms and the cathode resistor is around 560 ohms. This produces a bias of around 5½ volts with about 175 volts on the plates, assuming a supply of around 440 volts. The tube manuals indicate that the 6SN7 should be operated with 250 volts on the plate and an 8½-volt bias.

All you have to do is change that cathode bias resistor from its present value to 1000 ohms. A resistor of 1200 ohms works well, too. With a 1000-ohm bias resistor, there will be about 250 volts at the driver plates and the bias will rise to approximately 9 volts. Not only does this cut distortion but it means you can produce more drive voltage. Naturally, too, you can now put more signal voltage into the 6SN7 driver before it starts to draw grid current. The driver will stay class A, in fact long after the output stage has finally given up.

This change alone, of course, will not eliminate the distortion fed into the output stage. The first two stages are still underbiased and they hang together because of the d.c. coupling between them.

Let's start with the first stage. The bias resistor usually found there is 470 ohms. This should be increased to twice its value—simply add another 470-ohm resistor in series with the first. This raises the bias to around 3 volts, but increasing this bias causes the plate voltage of this stage to go up, thereby decreasing the grid-cathode bias across the phase-inverter—the next stage.

There are now two things to be done: lower the supply voltage to the first stage and increase the supply voltage to the phase-inverter. If each of these is changed in the right proportion, both stages will be biased correctly.

The average Williamson circuit uses a 33,000-ohm resistor from the 450-volt supply point to decouple the first stage; this must be increased to about 47,000

Fig. 1. Reduction in intermodulation distortion of the amplifier shown in Fig. 2.

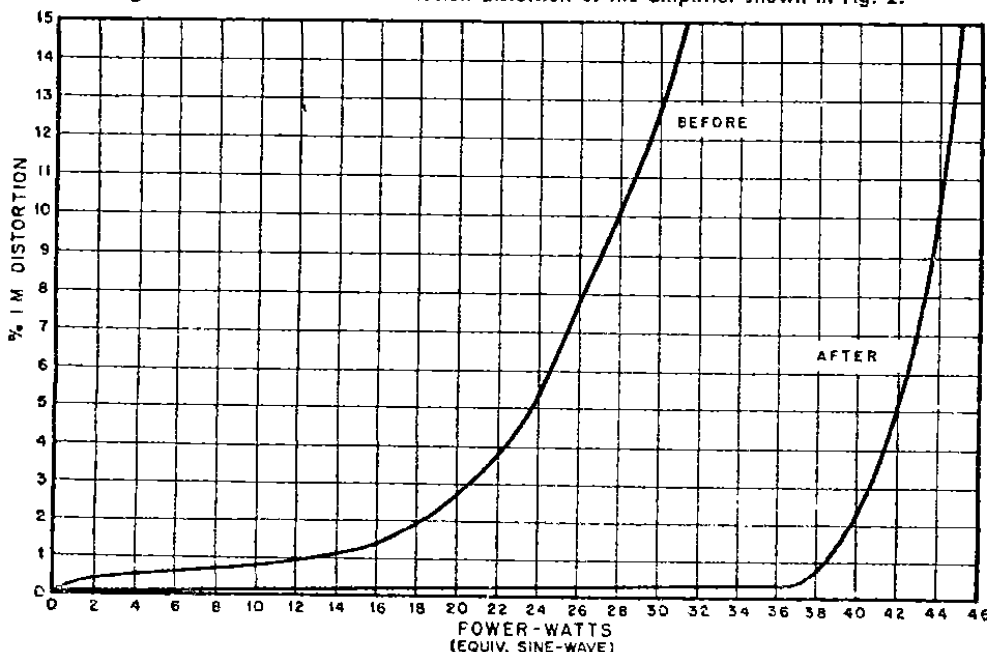

ohms. This will cut the current through the stage somewhat, producing a cathode bias of around 2½ volts, and it will also lower the plate voltage. The decoupling resistor to the phase-inverter is usually 22,000 ohms from the 450-volt point. This resistor should be reduced to 3900 ohms, pulling more current through the phase-inverter and raising the cathode bias.

When these last two changes have been made there should be about a 5½- to 7-volt bias from grid to cathode of the phase-inverter. Of course, if the initial supply voltage is much below 450 you will not get exactly the right bias, but it will be close enough to allow the first two stages to bias each other correctly. Typical voltages for this circuit are found in Fig. 2.

The net result of all these changes is to almost double the drive voltage available to the grids of the output tubes.

With a 450-volt supply you can get well over 100 volts to each grid. With a 400-volt supply that drops to something near 350 volts due to lack of regulation in the power supply, you should still be able to get 80 volts of drive per grid.

There is one thing more which must be done before you have the amplifier operating correctly. The output transformers used in Williamson amplifiers will not usually handle more than about 20 db of feedback, but increasing the resistor to the cathode of the first stage has already increased the feedback. Since the value of the cathode resistor has been doubled, it is necessary to double the value of the feedback resistor to put the feedback at its previous value.

With the changes outlined, any "Ultra-Linear"-type Williamson should not produce 1% distortion until it reaches overload. If the drive voltages to the grids of the output tubes are balanced,

the distortion should be well below 0.5%. Performance of the amplifier of Fig. 2 is illustrated in the curve of Fig. 1. For all IM tests, the generator supplied frequencies of 60 and 6000 cps at a ratio of 4 to 1. Readers should not be too concerned about the absolute values of power indicated nor a comparison of the power in one amplifier we have worked on with another. The important thing being shown here is the definite improvement in performance that occurred with the changes incorporated.

Amplifier No. 2 (see Fig. 3) uses four 5881's in a push-pull parallel triode output stage. In this one only the biasing modifications have been made. The tubes were chosen at random and no attempt was made to balance the drives beyond the tolerances provided by the 5-year-old 5% resistors already in the circuit. A 450-volt capacitor-input power supply was used in this circuit.

Fig. 2. Circuit of one of the amplifiers modified by the author. The values of five resistors have been changed.

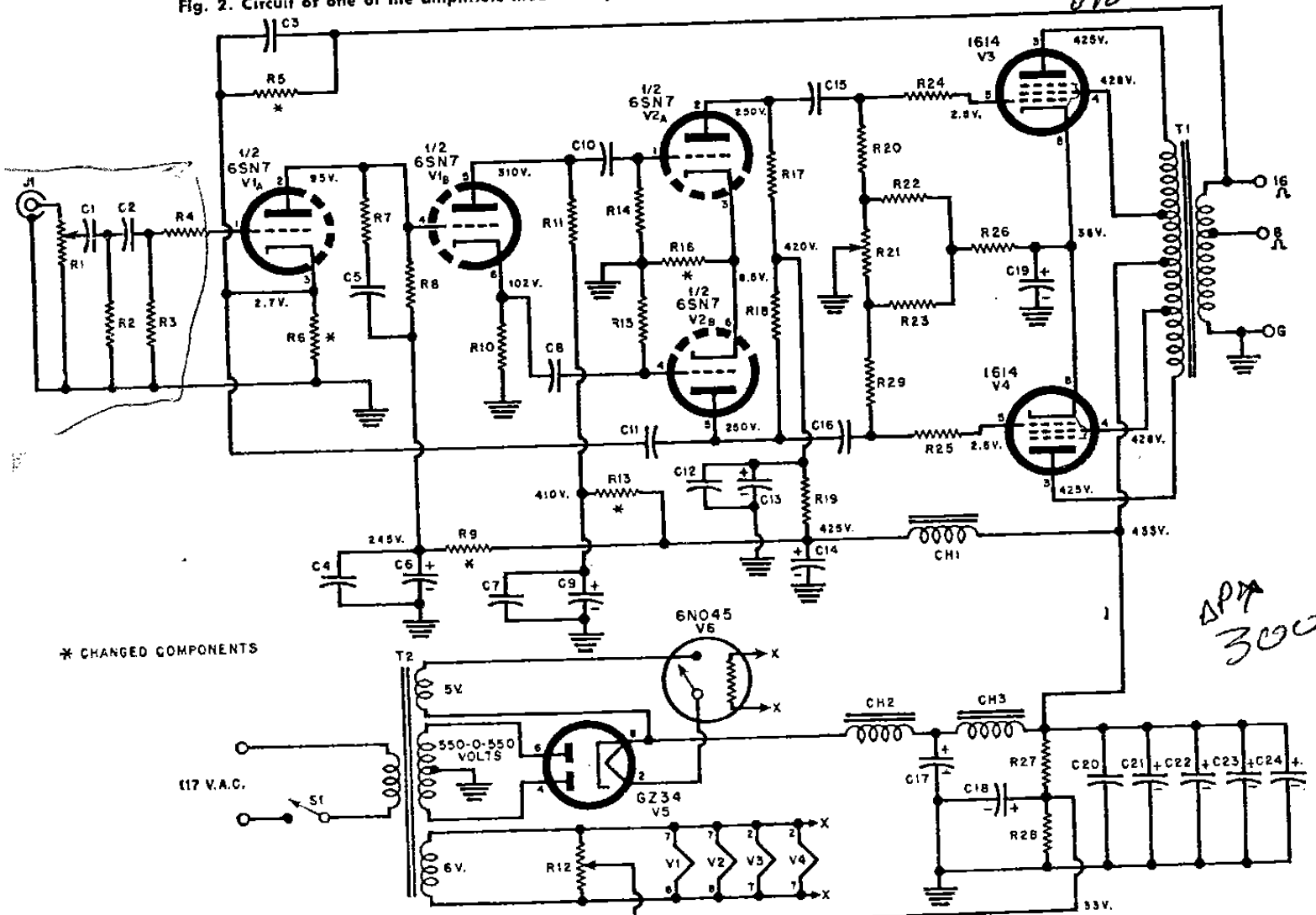

* CHANGED COMPONENTS

- R₁—1 megohm audio taper pot
- R₂, R₃—1.5 megohm, ½ w. res.
- R₄, R₅—10,000 ohm, ½ w. res.
- R₆—18,000 ohm, ½ w. res.
- R₇—910 ohm, 2 w. res.
- R₈, R₉, R₁₀, R₁₁—47,000 ohm, 2 w. res.
- R₁₂, R₁₃—22,000 ohm, 2 w. res.
- R₁₄—200 ohm, 4 w. wirewound res.
- R₁₅—3900 ohm, 2 w. res.
- R₁₆, R₁₇—470,000 ohm, ½ w. res.
- R₁₈—1000 ohm, 2 w. res.
- R₁₉—150 ohm, 2 w. res.
- R₂₀, R₂₁—100,000 ohm, ½ w. res.
- R₂₂—100 ohm pot
- R₂₃, R₂₄—100 ohm, 2 w. res.
- R₂₅, R₂₆—1000 ohm, ½ w. res.

- R₂₇—250 ohm, 10 w. wirewound res.
- R₂₈—220,000 ohm, 1 w. res.
- R₂₉—18,000 ohm, 1 w. res.
- C₁, C₂—1 µf., 400 v. capacitor
- C₃—75 µµf., 400 v. capacitor
- C₄, C₅, C₆—0.1 µf., 400 v. capacitor
- C₇—560 µµf., 400 v. capacitor
- C₈—40 µf., 350 v. elec. capacitor
- C₉, C₁₀, C₁₁, C₁₂—25 µf., 400 v. capacitor
- C₁₃—100 µf., 450 v. elec. capacitor
- C₁₄—100 µf., 400 v. capacitor
- C₁₅—60 µf., 450 v. elec. capacitor
- C₁₆—40 µf., 450 v. elec. capacitor
- C₁₇—20 µf., 600 v. elec. capacitor
- C₁₈—50 µf., 50 v. elec. capacitor

- C₁₉—600 µf., 150 v. elec. capacitor
- C₂₀, C₂₁, C₂₂, C₂₃—90 µf., 500 v. elec. capacitor
- J₁—Phono jack
- CH₁—7 ky., 50 ma., 500 ohm choke
- CH₂, CH₃—8 kv., 80-100 ohm, 200 ma. choke
- S₁—S.p.s.t. switch
- T₁—Audio output trans. 6500 ohms to 8/16 ohms, 50 watts (Dyna A-420 or equiv.)
- T₂—Power trans. 550-0-550 v. @ 200 ma.; 5 v. @ 2 amps; 6.3 v. @ 3 amps.
- V₁, V₂—6SN7 tube
- V₃, V₄—1614 tube
- V₅—GZ34
- V₆—S.p.s.t., 6.3 v. normally open, .45 second delay relay (Amperite 6N045)

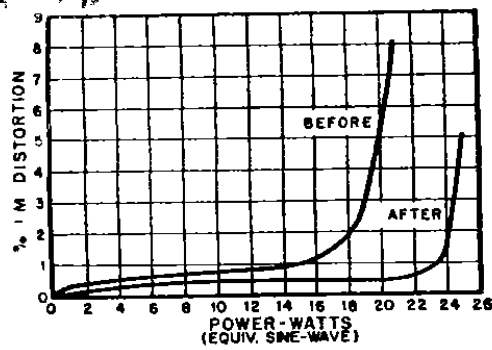

Fig. 3. Improvement in performance of amplifier using four 5881's in triode connection.

Amplifier No. 3 (see Fig. 4) uses two EL34/6CA7's connected as pentodes with a 250-ohm self-bias resistor and 5000-ohm plate-to-plate load. Again, no special effort was made to balance the drives. A 450-volt choke-input filter was used here.

Transient Response

All of the foregoing will cut distortion dramatically, but we have yet another problem to face: transient response. Improvement in an amplifier's transient response is usually more striking than improvement in distortion. Now, the high-frequency response of many Williamson amplifiers is ragged at best and it is nearly impossible to give a set of values to smooth the high end of all these units. However, the values given in Fig. 2 will be about right for an "Ultra-Linear"-type Williamson using either *Stancor* or *Dynaco* transformers. The RC values bypassing the plate load of the first stage aren't too critical. The small capacitive feedback loop from the plate of the lower driver to the cathode of the first stage is also non-critical. However, the value of the capacitor should not exceed 100 μf . The only value that must be juggled with extreme care is the capacitor across the feedback resistor. About 50 μf . to 150 μf . is usual in this position. The only

way to optimize the high-frequency response of the amplifier is to use an oscilloscope when making adjustments. In practically all cases, however, there will be no audible difference between results derived from using the given values and those derived from individual trimming.

The low-frequency transient response of the Williamson is less critical and easier to straighten out. Many amplifiers tend to get "bloopy" when hit by high-intensity, low-frequency sounds, due mainly to inadequate decoupling of the "B+." It is recommended that all of the stages be decoupled by at least 40 μf ., although in these amplifiers one of the (surprisingly) critical points is the phase inverter which should be more heavily decoupled. The now 3900-ohm resistor decoupling the phase splitter should be bypassed with an electrolytic whose value is in the neighborhood of 80 to 100 μf . These changes will produce a stable amplifier if you have used a good output transformer.

Now that the amplifier has been stabilized, let's try to further improve the low-frequency transient response. The capacitor bypassing the cathode resistor of the output stage is usually somewhere between 20 μf . and 250 μf . Use of the 250- μf . capacitor bypasses the stage to around 6 cycles, that is, the stage is flat to about 10 cycles. Low-pitched musical waveshapes contain near-d.c. components and in order to handle these adequately you must have the output stage bypassed to approximately 1/10th of the lowest frequency you wish to reproduce. If you want to have good transient response below 60 cycles, you have to bypass the output stage more heavily than 250 μf . Capacity of 500-600 μf . (made up of a couple of 300- μf . electrolytics in parallel) will bypass the output stage to about 3 cycles and will give good transient response to around 30 cycles. It is a rare speaker system that can produce 30 cycles and it is a rare room that will sustain that low a note even if the speaker is capable of

producing that note in the first place.

One word of caution: the use of very large bypassing values, 1000 μf . for example, may again lead to instability.

Other Improvements

A Williamson amplifier incorporating the modifications already outlined will sound good indeed but there is one additional thing you may do if you want to be "elegant." Any "Ultra-Linear"-type Williamson—even one with a choke-input power supply—will display a drop in "B+" during extremely loud passages. This has a limiting effect on the power output and the amplifier may not recover from overloads as quickly as you'd like. The remedy is to decouple the output stage more heavily. It has been found that four 90- μf . electrolytics connected across the center-tap of the output transformer will provide superb transient response. These capacitors hold enough of a charge to supply the output tubes with plenty of current during short-duration, high-intensity sounds and prevent a drop in "B+." The amplifier shown in Fig. 2 does not display the slightest change in "B+" until it is operating almost continuously in overload. The effect of this is most noticeable on low-frequency transients. Also, it will give the amplifier practically instantaneous overload recovery.

Changing the bypassing of the output-stage cathode and increasing the output-stage decoupling will likely produce no audible changes unless you have a really fine speaker system. With such a system, the improvement is readily apparent.

Of course, neither of the last two modifications is of much value if the phono preamp does not equalize correctly at the very low frequencies. Unfortunately, many preamps don't. The boost applied below 100 cycles in the RIAA curve is a help, but many record companies do not always apply the presumed low-frequency pre-emphasis. A discussion of equalization and tone-control is beyond the scope of this article, so we will assume that you can get the lows into your amplifier.

The modifications outlined can be made for around \$10 and, in view of the improvement in performance, are well worth the money. It is not the author's intention to disparage the original Williamson amplifier design—it has much to recommend it. It is easy to build and by re-biasing the voltage-amplifiers it becomes non-critical of tube selection. Furthermore, the "Ultra-Linear" version is capable of delivering all the clean power needed to drive any speaker system except for some of the less efficient—although excellent—bookshelf types.

The use of a choke-input power supply combined with the additional bypassing and decoupling will permit the "Ultra-Linear"-type Williamson to deliver several watts more than ordinary circuitry permits. The distortion won't exceed 1% until you reach overload and will sound as though you have doubled the power output when what you have done is improve the overload performance.

Fig. 4. Performance of another amplifier modified by author. This one utilized a pair of EL34/6CA7's with cathode bias and a choke-input filter in the power supply.

