

The White POWRTRON Amplifier

STANLEY WHITE*

A discussion of one possible cause of power distortion and a description of a circuit developed to eliminate it. The author also describes his method of dividing the frequency spectrum ahead of the power amplifier. This unit has been popular with listeners at recent demonstrations.

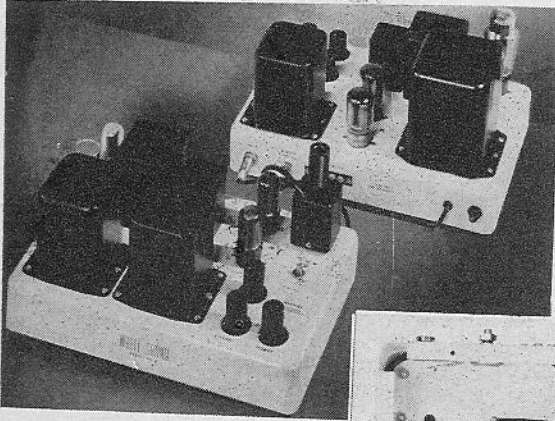

Fig. 1 (left). Top view of 10- and 20-watt White amplifiers with filter network plugged into the 10-watt unit. Fig. 3 provides for network to be plugged into the 20-watt low-frequency amplifier.

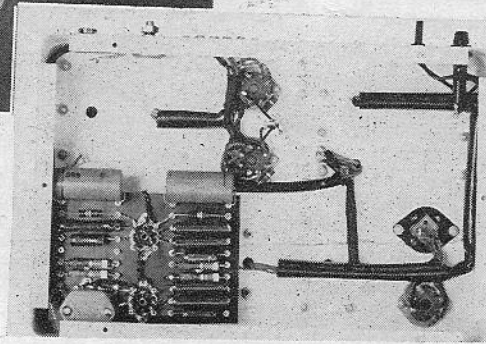

Fig. 2 (right). Underside view of the 20-watt amplifier. Large mica capacitor at lower left is C₁.

MOST AMPLIFIERS are developed and tested using pure resistive load impedances across the secondary of the output transformer. Determination of intermodulation distortion, harmonic distortion, and power performance are based upon results obtained using these resistive loads although it is well recognized that speakers do not present a constant load impedance over the entire frequency spectrum. However, for want of a better method, resistive loads have been retained as a standard procedure in determining the performance and operating characteristics of amplifiers.

This paper proposes a basic change in amplifier circuitry that is inevitable if amplifiers are to perform their basic function—that of presenting an electrical power waveform to a speaker in such a manner that the acoustical wave radiated from the surface of the speaker is a

(Continued on page 52)

*White Sound, Inc., 105 W. Madison Street, Chicago 2, Ill.

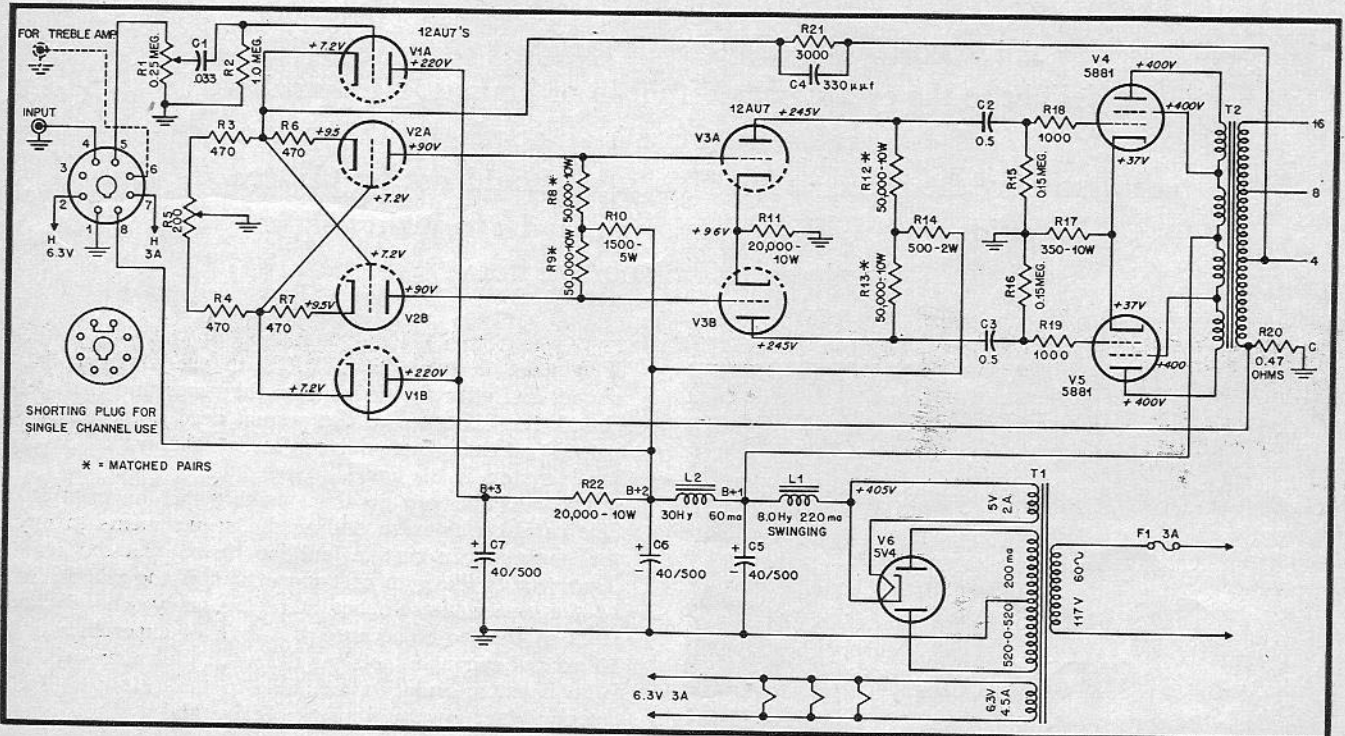

Fig. 3. Complete schematic of the 20-watt White amplifier arranged for plugging in the electronic filter network. 10-watt model is identical except for output tubes, which are 6V6's, and the output transformer.

Fleetwood

The Finest in
Remote Control

Television Receivers

with High Fidelity Audio Output

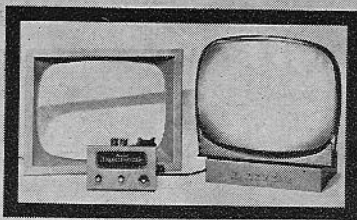

Complete 2-chassis system featuring the New 27" Rectangular Picture Tube

ALSO AVAILABLE FOR 21 AND 24 INCH PICTURE TUBES

For the finest in television picture quality, with the convenience of electronic remote control, enjoy the many features of the Fleetwood. A complete two chassis, full remote control television system, built to professional standards which provides high fidelity audio outputs to match the finest home music systems.

The separate tuner chassis, with edgelit dial and individual channel pilot lamps, includes off-on, volume, picture channel selection and fine tuning controls. The tuner is

of the Super Cascode type, completely adaptable to UHF by simple interchange of strips. UHF provision on tuner dial. Four I. F. Stages and full 4 megacycle band-pass. Separate cathode followers for audio and video. Audio Outputs: 4 watts for loudspeaker; both high impedance and cathode-follower for connection to existing amplifier.

Both Tuner and Picture Chassis attractively finished in gray and black baked enamel.

Also available without remote control.
SEE YOUR LOCAL JOBBER OR WRITE

CONRAC, INC. Since 1939 • Glendora, California

Nearly everybody reads the audio anthology

and

the 2nd audio anthology

The original audio anthology is still being ordered by people who have worn out their first copy or who have just learned about the book. Contains reprints of 37 articles which appeared in AUDIO ENGINEERING from May 1947 through December 1949. An invaluable reference work on audio in the home.

the 2nd audio anthology continues from where the first left off and contains reprints of articles from January 1950 through July 1952. In both books the articles were brought up to date, corrected where necessary, and assembled by subject. the 2nd a a may still be had with board cover.

CUT OUT — MAIL TODAY

Book Division, Dept. 3V,
Radio Magazines, Inc.,
P. O. Box 629, Mineola, N. Y.

Sirs: Enclosed is check money order for \$..... Please send me
..... copies of audio anthology (paper cover) @ \$2.00 each
..... copies of the 2nd audio anthology (paper cover) @ \$2.00 each
..... copies of the 2nd audio anthology (board cover) @ \$3.00 each

Name (please print)

Address

City Zone State

The POWTRON

(from page 32)

transformed replica of the voltage waveform at the input to the audio amplifier. It will be shown that present audio amplifiers create a power distortion of a magnitude of 6 to 8 db, and this type of distortion is not discernible by present day testing procedures.

Definition 1. Power distortion: A power waveform generated by an audio amplifier that deviates in any manner whatsoever from the form of the input voltage waveform is distorted with respect to power to the extent of the deviation.

From this definition, it can be seen that any distortion measurement of an audio power amplifier is, in fact, a measurement of power distortion. That is, power distortion is a generalized form covering intermodulation distortion, harmonic distortion, and so on. Any amplifier that changes its power output with changing load impedance suffers from power distortion to the extent that the power output is altered. It is recognized that the relationship between power, voltage, and impedance can be expressed by the formula

$$P = \frac{E^2}{Z} \quad (1)$$

where P = power output,
 E = voltage, and
 Z = load impedance.

In test procedures using resistive loads, it can be seen that if E remains constant, the power output will remain constant. However, with variable load impedances the power output will bear an inverse relationship to the impedance.

From transducer theory, there are certain relationships between the electrical and acoustical characteristics of any speaker, and such factors as the resistance of the suspension system, the resistance of the air load, the reactance of the voice coil and cone, the reactance of the air load, and the reactance of the suspension system must be considered as affecting the total impedance of the speaker, in addition to the pure electrical impedance of the voice coil itself.

Effect of Feedback

The majority of hi-fi amplifiers employ some form of voltage feedback, but a study of equation (1) will show that if voltage remains constant there will be considerable power distortion, and it is agreed that voltage feedback tends to hold the voltage constant regardless of the load across the amplifier terminals. Thus any change in load impedance results simultaneously in an inverse power change. If electrical impedance characteristics and acoustical output characteristics of a given speaker were related in such a manner that electrical impedance peaks occurred simultaneously with acoustical peaks, the decrease in power response at the point of maximum acous-

tical output would be beneficial. However, in real speakers this condition seldom occurs.

The Powrtron circuit, Fig. 3, differs from conventional amplifiers in that it adds a small amount of negative current feedback to a usual amount of negative voltage feedback, with the result that over a reasonable range of load variations the power distortion is held to 1 db, whereas without the Powrtron feature the same amplifier shows a distortion of as much as 8 db.

Careful consideration of this will show that it is useless to attempt to control the behavior of a loudspeaker by means of a device that will sense impedance changes in the speaker, and this is exactly what is done with voltage feedback. Many other effects of voltage feedback are definitely beneficial, as is well known, but the effect on power distortion is to increase instead of decrease it.

Negative power feedback results in much less power change over a range of output loads than the other methods of operation. Positive current feedback reduces the internal impedance of power amplifiers to zero, but by so doing it increases power distortion.

The Complete Circuit

While the Powrtron circuit refers only to the addition of a single resistor in the output circuit and the connection back to a suitable point for the introduction of feedback, there are some advantages to the complete White amplifier and the method of introducing two separate kinds of feedback is simplified greatly. In Fig. 3 it will be noted that R_{21} and C_4 constitute a usual form of negative voltage feedback. The negative current feedback is obtained from R_{20} in the return leg of the secondary of the output transformer. The cross-coupled phase inverter, together with the direct-coupled driver stage make it possible to introduce the two different types of feedback with considerable ease. Furthermore, if a direct A-B test is desired, it is only necessary to short out R_{20} .

Since the circuit is somewhat unique, it may bear explanation. The input is fed into a level-adjusting potentiometer and thence to the grid of V_{1a} through C_1 and the grid resistor R_2 . (The use of the octal socket will be described later.) C_1 and R_2 may appear unnecessary, but the slightest amount of d.c. on the grid of V_{1a} is sufficient to unbalance the operation of the entire system so C_1 is a mica capacitor—.033 μ f or larger—which has been found to be completely free from leakage. The cathode of V_{1a} is directly coupled to the grid of V_{2b} and a tap on the cathode resistor string of V_{2a} . R_5 provides for a balance of d.c. voltages throughout the first three tubes—the method of adjustment being to set R_5 at a point where the voltage between the plates of V_{3a} and V_{3b} is zero. The negative current feedback is connected to the grid of V_{1b} —directly out of phase with the input section—and the output of V_{1b} is fed into the phase splitter in a manner similar to that from V_{1a} . The direct coup-

Here's how to make HIGH FIDELITY mean what it says!

JUST OUT!

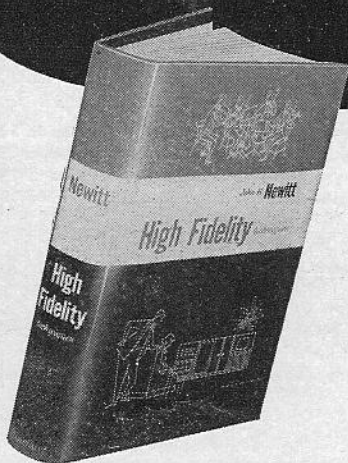

HIGH FIDELITY TECHNIQUES

by John H. Newitt

Staff, Mass. Inst. of Technology
494 pages, 203 illustrations
Price \$7.50

A COMPLETE GUIDE TO BETTER HIGH-FIDELITY EQUIPMENT, CIRCUITS, CONSTRUCTION, SERVICE and better results!

Get better results from "hi-fi" by having all of the facts and latest ideas at your fingertips!

This big new book by one of the nation's acknowledged experts brings you the complete "low-down" on modern sound reproduction methods and equipment. It shows exactly how to get best results at minimum cost; discusses all details of circuitry, components and equipment; covers the service angles; compares the different methods—and is chock full of how-to-do-it tips and ideas.

ANSWERS YOUR QUESTIONS ABOUT HI-FI Chock full of how-to-do-it tips and ideas

Here are just a few of the subjects covered: What to look for in high-fidelity equipment—what to avoid • Getting reproduction to suit your taste • Some unusual "hi-fi" combinations • Hi-fi vs. P.A. type speakers • Matching the reproducer to its environment • Loudspeaker construction and performance • Adjusting bass-reflex cabinets • Controlling distortion • A novel horn system • Baffles • Getting rid of "overhang" • The best reproducer enclosure • Choosing a reproducer • Selecting a woofer-tweeter combination • Sound-proofing materials • How grillwork affects attenuation • Output transformer specifications and what they mean • Special hi-fi circuits • Proper crossover frequencies • Do's and don'ts of volume expansion • Practical ways to suppress noise • A good tone control • Negative feedback and how to use it • Pre-amps and equalizers • Amplifier construction hints • Judging commercial amplifiers • F-M tuners • Minimizing tuner distortion • Avoiding chatter and crosstalk • Limiter-discriminator vs. ratio detector FM circuits • All about records and record players • Selecting turntables and pick-up cartridges • Avoiding record wear • A comprehensive course in magnetic recording • Pick-up resonance, its cause and cure • Choosing a recorder • Tips for custom builders • Special installation problems • Typical "hi-fi" installations • Bass-reflex calculations and design charts • Acoustical horn design data . . . and dozens of other subjects.

Read it for 10 days AT OUR RISK! Use coupon.

**10-DAY
FREE
EXAMINATION**

Dept. AE-113, Rinehart Books, Inc., Technical Division
232 Madison Ave., New York 16, N. Y.

Send HIGH FIDELITY TECHNIQUES by Newitt for 10-day FREE examination. If I decide to keep the book, I will then remit \$7.50 plus postage. Otherwise, I will return book postpaid promptly and owe you nothing. (If you send cash with order, we pay postage—same return privilege with money refunded.)

Name
Address
City, Zone, State

OUTSIDE U.S.A.—Price \$8.00, cash only. Money back if book is returned postpaid in 10 days.

HYCOR TYPE 4201 PROGRAM EQUALIZER



Features . . .

- **LOW HUM PICKUP** through the use of toroid coils.
- **Switch contact noises** are inaudible even at microphone levels.
- **Low frequency equalization** peaked at 40 cycles and 100 cycles in 2 db steps up to 12 db.
- **High frequency equalization** peaked at 3 kc, 5 kc and 10 kc in 2 db steps up to 12 db.
- **Low frequency attenuation** in 2 db steps at 100 cycles and has a maximum attenuation of 16 db.
- **High frequency attenuation** in 2 db steps at 10 kc and has a maximum attenuation of 16 db.

\$195.00

General Specifications . . .

- DIMENSIONS:** Standard rack panel, slotted, 3½" high. Maximum depth 7½".
- CIRCUIT:** Bridged "T" constant impedance.
- IMPEDANCE:** 500/600 ohms, in-out.
- INSERTION LOSS:** 14 db constant.
- CONTROLS:** Low and high frequency selector switches. Low and high frequency controls in 2 db steps, in-out key.
- FINISH:** Engraved panel, medium gray baked enamel. (Special colors and finishes upon request.)

HYCOR SALES COMPANY
of California

11423 VANOWEN STREET
NORTH HOLLYWOOD, CALIF.

Send for Bulletin E

Representatives:

BEEBE ASSOCIATES
5707 W. Lake St., Chicago, Illinois
BURLINCAME ASSOCIATES
103 Lafayette St., New York City
HARRISON J. BLIND
1616 Cord St., Indianapolis 24, Ind.

ling between the phase splitter section and the driver is made possible by the use of a very large cathode resistor for V_3 . It will be noted that these cathodes are about 96 volts above ground, resulting in a potential of approximately 90 volts on the plates of V_2 —this same voltage being applied to the grids of V_3 which results in a bias of around 6 volts.

The output stage is the Ultra-Linear, which has been described heretofore.¹ In the 20-watt White amplifier, 5881's are used; in a very similar design for 10 watts output, 6V6's are used—this

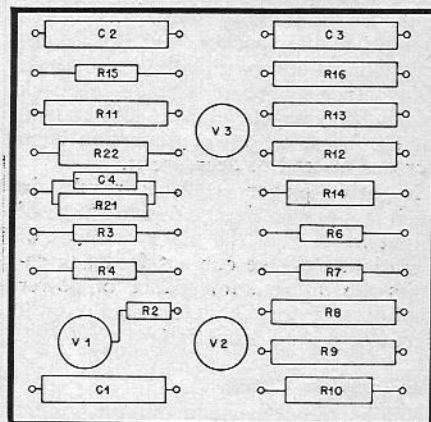

Fig. 4. Arrangement of parts on terminal board shown in Fig. 2.

latter amplifier being used with the 20-watt model to make the two-way amplifier system to be described.

The current feedback is developed across R_{20} , shown as 0.47 ohms. In construction, it is suggested that this value be obtained by the use of a 1-ohm 10-watt adjustable resistor. Slight variations in the power response characteristics may be had by changing the value of this resistor, with corresponding changes in the tonal quality of the output.

Figure 2 shows the underside of the White amplifier. Note that most of the components ahead of the output stage are located on the terminal board, which is laid out as in Fig. 4. The parts list indicates the wattages of the various resistors, as well as the types recommended.

In construction, it is suggested that the amplifier be assembled with semi-permanent connections between the driver stage and the output-tube grids, and with the negative-voltage feedback circuit— $R_{21}-C_4$ —disconnected. Then pass a signal through the amplifier and note whether the signal increases or decreases when R_{20} is shorted. If the signal decreases, the leads to the two output grids should be reversed, since the feedback voltage developed across R_{20} should reduce the gain, and shorting the resistor eliminates the feedback. After the correct polarity is determined, the voltage-feedback circuit $R_{21}-C_4$ may be connected.

¹ David Hafler and Herbert I. Keroes, "The Ultra-Linear amplifier." *AUDIO ENGINEERING*, Nov. 1951.

**STATEMENT OF THE OWNERSHIP, MANAGEMENT, AND CIRCULATION
REQUIRED BY THE ACT OF CONGRESS OF AUGUST 24, 1912, AS
AMENDED BY THE ACTS OF MARCH 3, 1933, AND JULY 2, 1946**

(Title 39, United States Code, Section 233)

of AUDIO ENGINEERING, published monthly at Lancaster, Pa., for October 1, 1953.

1. The names and address of the publisher, editor, managing editor, and business managers are: Publisher: Charles G. McProud, 204 Front St., Mineola, N. Y.; Editor: Charles G. McProud, 204 Front St., Mineola, N. Y.; Managing editor: none; Business manager: Henry A. Schober, 204 Front St., Mineola, N. Y.

2. The owner is: Radio Magazines, Inc., 204 Front St., Mineola, N. Y.; Henry A. Schober, 204 Front St., Mineola, N. Y.; Charles G. McProud, 204 Front St., Mineola, N. Y.

3. The known bondholders, mortgagees, and other security holders owning or holding 1 per cent or more of total amount of bonds, mortgages, or other securities are: none.

4. Paragraphs 2 and 3 include, in cases where the stockholder or security holder appears upon the books of the company as trustee or in any other fiduciary relation, the name of the person or corporation for whom such trustee is acting; also the statements in the two paragraphs show the affiant's full knowledge and belief as to the circumstances and conditions under which stockholders and security holders who do not appear upon the books of the company as trustees, hold stock and securities in a capacity other than that of a bona fide owner.

(Signed) HENRY A. SCHOBBER, Business Manager.

Sworn to and subscribed before me this 14th day of September, 1953.

(Seal) WILLIAM E. STOLT, Notary Public.

State of New York, No. 30-9205000. Qualified in Nassau County. My term expires Mar. 30, 1954.



Broadcast Utility AMPLIFIER

FOR USE AS:
Microphone Pre-Amplifier
Booster Amplifier
Cuing Amplifier, etc.

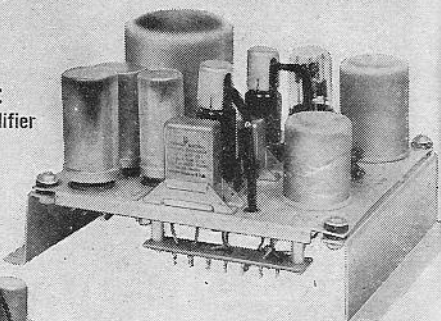
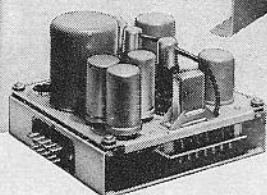

Type BA-10-A

Mount on FA-26-A adaptor
for plug-in unit!

GAIN 50 db maximum

FREQUENCY RESPONSE ± 1 db, 50 to 15,000 cps

OUTPUT LEVEL -2 dbm, with 1/2% or less distortion

COMPACT AC operated, self-contained power supply

For information write: General Electric Company
Section 44113, Electronics Park, Syracuse, New York

GENERAL ELECTRIC

ENJOY THE FULL RICHNESS
OF FULL FREQUENCY RECORDING . . .

The FAIRCHILD

SERIES 215

HIGH-COMPLIANCE

Diamond Cartridge

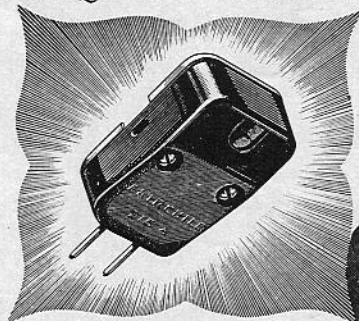

This amazing new cartridge, a radical departure from ordinary cartridge design, achieves near-zero mass of stylus assembly. The result is **HIGH COMPLIANCE**—accurate, distortion-free tracking which reproduces without listening fatigue the full, rich tonal qualities of the most sensitive recordings.

"Amazed at new purity of sound . . . clarity . . . distinctness of orchestral texture . . . which all add up to something fabulously beautiful!" says B. H. Haggin, noted Record Reviewer.

NOW ONLY
\$37.50
WITH FINEST
DIAMOND STYLUS

FAIRCHILD RECORDING EQUIPMENT:

9th Ave. & 154th St.,
Whitestone, N. Y.

Manufacturers of the "World's Finest Professional Sound Equipment"

ORDER FROM YOUR
AUDIO DEALER
or mail coupon for
FREE folder

Without obligation, please mail FREE folder, "HI-FI FACTS for the Music Lover"

Name
Address
City State

of filter sections capable of dealing with the variable impedance presented by a speaker is a problem of serious magnitude. The use of a dual-channel amplifier using electronic filter sections at the input of the system is deemed the best solution.

The crossover filter is constructed in a standard Vector CO-10-N turret can, making it readily interchangeable. Thus the experimenter can construct several different filter networks to determine the best operating crossover frequency for the speakers used, or by removing the network can restore the amplifier to normal operation with a minimum of effort. For the constants shown, the crossover frequency is approximately 560 cps.

In the hi-fi field the final judgement is always that of the listening test. In the case of amplifiers it is difficult to achieve a distinct improvement, but it is felt that a listening test with the crossover amplifier will give the listener just such a distinct improvement.

PARTS LIST (Fig. 3)

- | | |
|------------------|---|
| C_1 | .033 μ f, 1200 v. mica |
| C_2, C_3 | 0.5 μ f, 600 v. paper |
| C_4 | 330 μ f, 500 v. mica |
| C_5, C_6, C_7 | 40 μ f, 500 v. elect. |
| L_1 | 8 H, 220 ma, swinging choke |
| L_2 | 30 H, 60 ma, smoothing choke |
| R_1 | 0.25 meg potentiometer, audio taper |
| R_2 | 1.0 meg, 1/2-watt, deposited carbon |
| R_3, R_1, R_6 | 470 ohms, 1-watt, wirewound |
| R_4 | 200 ohms, 4-watt potentiometer, linear |
| R_8, R_9 | 50,000 ohms, 10-watt, wirewound, matched pair |
| R_{10} | 1500 ohms, 5-watt, wirewound |
| R_{11} | 20,000 ohms, 10-watt, wirewound |
| R_{12}, R_{13} | 50,000 ohms, 10-watt, wirewound, matched pair |
| R_{14} | 500 ohms, 2-watt, wirewound |
| R_{15}, R_{16} | 0.15 meg, 1-watt, deposited carbon |
| R_{17} | 350 ohms, 10-watt, wirewound |
| R_{18}, R_{19} | 1000 ohms, 1/2-watt, deposited carbon |
| R_{20} | 1.0 ohms, 10-watt, adjustable, wirewound |
| R_{21} | 3000 ohms, 1-watt, wirewound |
| R_{22} | 20,000 ohms, 10-watt, wirewound |
| T_1 | Power transformer, White Sound or Chicago PCR-200. 520-0-520 v at 200 ma; 5.0 v at 2.0 a; 6.3 v at 4.5 a; potted. |
| T_2 | Ultra-Linear output transformer, Acro TO-300, or White Sound |
| V_1, V_2, V_3 | 12AU7 |
| V_4, V_5 | 5881 or KT66 |
| V_6 | 5V4 |

PARTS LIST (Fig. 5)

- | | |
|--------------------|---|
| C_1, C_3 | .05 μ f, 600 v. paper |
| C_4, C_5, C_6 | 750 μ f, 500 v. mica |
| C_7 | 750 μ f, 500 v. mica |
| C_8, C_9, C_{10} | .005 μ f, 500 v. mica |
| C_{11} | 1.0 meg, 1/2-watt, deposited carbon |
| R_1, R_{12} | 1500 ohms, 10-watt, wirewound |
| R_2, R_3 | 47,000 ohms, 1/2-watt, deposited carbon |
| R_4, R_5, R_6 | 47,000 ohms, 1/2-watt, deposited carbon |
| R_7 | 0.47 meg, 1/2-watt, deposited carbon |
| R_8, R_9, R_{10} | 0.47 meg, 1/2-watt, deposited carbon |
| R_{11} | 12AU7 |
| V_1 | 12AU7 |