

ideal for all stereo records but will not properly play all early monos. (There is no universal stylus.)

To sum up then, the Marantz SLT-12 is a truly fine product. It has been designed to be representative of state-of-the-art performance. It does not fall short of that goal.

CIRCLE 1

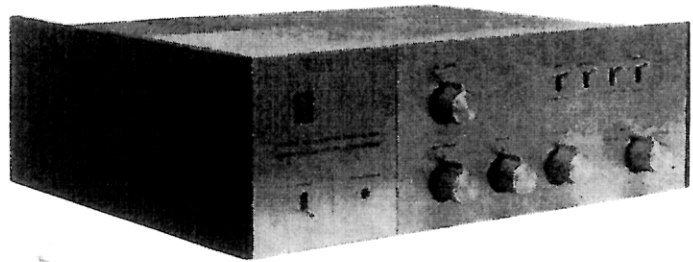

Fig. 2. The JBL SA 600 Integrated Amplifier.

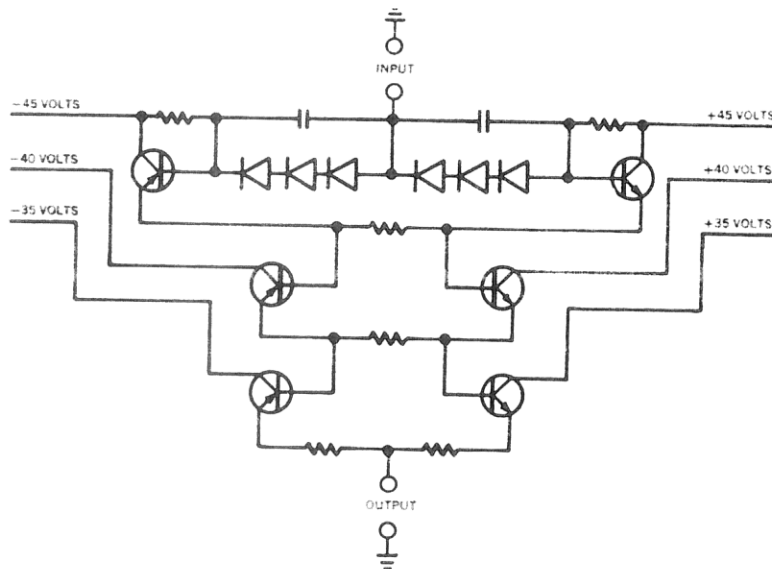

Fig. 3. The SA 600 output circuitry. The derivation of the term "T" circuit can readily be seen in this configuration. Note that coupling is direct. However, there is an extreme-bass attenuation capacitor in the first stage of amplification.

### JBL SA 600 INTEGRATED AMPLIFIER

All-transistor stereo amplifiers are coming at us thick and fast. And these days they are pretty good. It is not correct to say that transistor products are inferior (in some respects, at least) to vacuum-tube products. Quite the contrary, we have seen several innovations in solid-state gear that would not have been readily possible an era ago. This JBL SA 600 is a case in point.

It is compact and not too heavy. It is a versatile integrated amplifier of high power output and excellent performance. Yet distortion, particularly IM distortion, was so low that it was straining the lower reaches of our instruments to measure it. To wit:

0.1 watt	0.07 per cent
1 watt	0.05
10 watts	0.05
20 watts	0.08
40 watts	0.23

These figures have been taken with an 8-ohm load and with both channels driven simultaneously. That is good performance by any standard.

The SA600 is not overburdened by a surfeit of knobs and controls. Still, nothing is really missing. Bass and treble control has been combined into two knobs each controlling both channels together. In this day of stereo via identical speaker sets we can not fault this elimination of separate channel control of tone function.

However, when versatility really counts, it is there in abundance. The tape-head input may be used as such, or, via a rear switch, it is convertible into a second RIAA phono input. The primary magnetic phono input offers considerable flexibility. JBL recognizes that many cartridges are not equal in output on the two channels. So they provide a rear-panel balance control just for phono. JBL also recognizes that cartridges of today offer outputs ranging from 2 mV to over ten times that amount. So the rear panel contains a three-position switch labelled LOW, MEDIUM, and HIGH. 4, 8, or 16-mV inputs will result in full output of the amplifiers. Overload is in excess of 250 mV at the HIGH settings; there will be no phono overload problem here.

There is a most interesting feature operated by the second-from-left toggle switch. In its normal position it does nothing. But swing it to TEST with a mono input source and adjust the front-panel balance control for the optimum null. This is electrical balance of the two channels.

But the true virtues of the SA 600 are to be found on the test bench and in the listening room. Power response of the unit is claimed at 40 watts per channel into 8 ohms. We measured 48 watts at mid frequencies, 45 watts at 20 kHz, and 47 watts at 20 Hz. (At 16 ohms the amplifier will deliver 25 watts per channel; at 4 ohms it is over 60 watts.)

All of these measurements have been made with both channels driven.

Frequency response may be drawn with a ruler between the usual 20-20,000 Hz limits. In fact, the ruler may be considerably extended. We found the -2-dB points to be at 8 Hz on the low end and 160 kHz at the upper end. Rise time was a fast 2.5  $\mu$ sec. Noise was 81 dB below 40 watts at the high-level inputs. A check of RIAA accuracy showed it to be within a dB of ideal over the 30-15,000 Hz range. Cross talk at 20 kHz was better than -45 dB with the "worst case" measurement.

That we are dealing with an impressive product is proven when the unit is installed into a quality music system and subjected to the test of the ears. If there are any faults to be found, they will show here!

We should expect that this amplifier would sound satisfactory. In point of fact it does not sound satisfactory—it does not create sound at all. That cliché about hearing *through* amplifiers has never been more apt than here. The SA600 can truly be called an "undistinguished" product. And that is what a great amplifier should be.

CIRCLE 2

### HEATHKIT LABORATORY OSCILLOSCOPE, MODEL 10-14

Every electronic technician and tinkerer knows (or should know) the value of a good oscilloscope. Most of the ones seen are quite adequate to observe a waveform